

## UHV BAYARD-ALPERT GAUGE CONTROLLER MODEL NGC2

AML's NGC2 UHV BA controller is a powerful new-generation instrument, which has improved performance compared to PGC1 and PGC2, which it replaces. In 98% of cases it is a direct, plug-in replacement. Operation is even simpler, and more resistant to student-abuse. It has a longer, brighter LED display. All functions and setup are available from the front panel. Two fans are fitted, used alternately and monitored for performance.

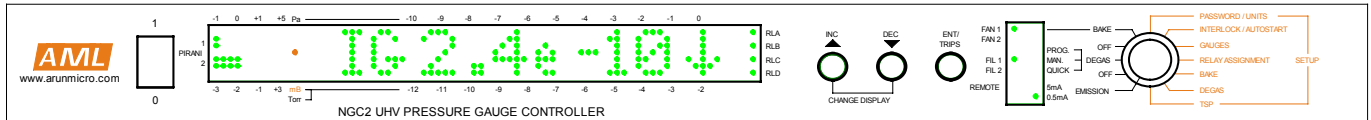

- ◆ 1U high full-width, steel-cased instrument for easy rack-mounting. Operates on 100 to 240v, 50/60Hz lines without adjustment.
- ◆ Controls 1 BA gauge plus 2 AML Pirani gauges plus a Capacitance Manometer simultaneously.
- ◆ Continuous measurement range: 1 Bar to  $3 \times 10^{-11}$  millibar.
- ◆ AML and approved equivalent gaugeheads may be exchanged or lead lengths altered without adjustment. Many other BA gauges are suitable.
- ◆ Filament current limit automatically set for filament material. Filament in use selected from the front panel. Ion gauge is grounded when not operating.
- ◆ Variable BA gauge sensitivity.
- ◆◆ Reduced emission current. Instrument advises optimum emission current at low pressure.
- ◆ Automatic start of BA gauge in pump-down.
- ◆ BA gauge interlock by Pirani or external signal (contact closure).
- ◆◆ Electron-bombardment degas program with independent adjustment of ramp, power and dwell time. Variable "quick" degas program with ramped start. Manual degas. Excessive or inappropriate degas is limited or inhibited.
- ◆◆ Pirani gauges may be switched on or off from the front panel.
- ◆◆ Comprehensive temperature management, with early indication of the need to replace a fan. Failure of a single fan does not inhibit use.
- ◆ Bright green LED display shows bargraph or numeric pressure, trend, diagnostics, etc.. Display in mBar, Torr or Pascal. Permanent bargraph of Pirani pressures.
- ◆ Simple, guided-setup is re-entrant and divided by function. Setup can be password-protected.
- ◆◆ Preset adjustable bakeout program with control of temperature, time and overpressure limit. Integral K-thermocouple amplifier.
- ◆◆ Automatic control of sublimation pump with countdown/cancellation of imminent firing.
- ◆ Integral, variable-sensitivity leak detector with audio output on Pirani1 or ion gauge.
- ◆◆ 4 internal power relays (5A, 240V) flexibly-assignable to gauges from the front panel. All external relay wiring is connected through a pluggable screw terminal block, which has a retaining safety shield.
- ◆◆ Non-volatile relay setpoints with manual override and inhibit facility. Simple setpoint adjustment and interrogation while measuring pressure.
- ◆◆ RS232-compatible interface for data-logging and control (cost - option).
- ◆ Recorder output 1.0 volt/decade on pluggable, 4-way screw terminal block with capacitance manometer and inhibit signals.
- ◆ Supplied with a mains lead, relay and auxiliary connectors, spare fuse and brief user manual.
- ◆◆ Cost-saving packages including gauges, leads and extended warranty are available.

This document and the designs depicted are the copyright of Arun Microelectronics Ltd. Specifications are subject to change, confirm before ordering. E & OE. AML acknowledges the rights of the owners of all trademarks and registered names.

# AML

*innovation in vacuum technology*

## SPECIFICATION

## DIMENSIONS

<b>Nett Weight</b>	<b>3.5 kg</b>
<b>Shipping Weight</b>	<b>5.0 kg</b>
<b>Carton Dimensions</b>	<b>60 x 40 x 13 cm</b>

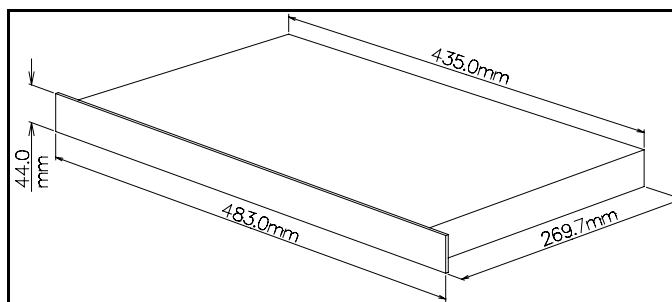

## BAYARD ALPERT GAUGE

- Types:** AML AIG17G is recommended. BA gauges from many other manufacturers are suitable, without adjustment other than sensitivity. A list of tested and approved gauges is available from AML. The use of non-approved gauges and leads may result in unstable emission or non-compliance with EU legal requirements and is not covered by AML's warranty.
- Range:** From  $1 \times 10^{-3}$  to below  $3 \times 10^{-11}$  mB with a UHV gaugehead with tungsten filaments. The low limit is dependent on gaugehead, cable construction and length and conditions of use. The upper limit is determined by the acceptable life of the filament and may be extended by the use of thoria or yttria-coated iridium filaments.
- Accuracy and Repeatability:** Determined principally by the gaugehead: controller errors are much smaller. Emission at 0.5mA is recommended. Electrometer logarithmic conformance <1% within any decade from 0.1 mA to 10 pA, <5% to 1 mA and <20% to 2 pA at 25°C incoming air temperature. Slope temperature compensation <0.02% per degree Celsius. Differential linearity of the 12-bit A to D converter is less than 0.1 LSB. Emission current initial accuracy <2%, stability <1%.
- Gauge Supplies:** Grid: +200 volts in emission, +500 volts at  $\leq 60$  mA in degas.  
Filament: +50 volt bias,  $\leq 12$  volts at  $\leq 4.2$  A (Tungsten)  $\leq 2.6$  A (Yttria) with filament power limited at > 30 watts.

## CAPACITANCE MANOMETER ( CM )

Capacitance Manometers of any manufacture having a +10 volt full-scale output at 1, 10, 100 or 1000 Torr or millibar and which are self-powered are suitable. Pressure indication can be in units different to the full-scale units defined for the Capacitance Manometer.

## PIRANI GAUGES.

AML types PVU2 and PVB2. A constant-voltage bridge circuit reduces contamination at high pressures. AML Pirani gaugeheads may be exchanged or extension leads may be connected without adjustments being necessary.

## GENERAL

- Pressure Display:** Scientific notation with a 2-digit mantissa for all gauges. Bargraph displays may be selected.
- Operating Temperature:** 5° to 35° Celsius for specified performance. Incoming air temperature is measured and displayed and operation is inhibited at >40°C.
- Supply Voltage:** 100 V to 240 V nominal at 48 to 65 Hz, without adjustment.
- Power Consumption:** <20 watts idling, <75watts in emission.
- EMC Compliance:** **Compliance with EU EMC Directive 89/336/EEC can only be guaranteed if AML BA gauge leads and screened Pirani gauges are used.**

AML pursues a policy of continuous product improvement and reserves the right to make detail changes to specifications without consultation. Unless otherwise stated all specifications are typical and at 25° Celsius, after 1 hour operation. E and OE.

**Ordering information:** **NGC2** Pressure Gauge Controller

**Related products:**

<b>AIG17G</b>	UHV Bayard-Alpert gauge, twin tungsten filaments
<b>AIGL3,(6),(9)</b>	3, (6), (9) metre, screened, bakeable BA gauge lead
<b>PVU2</b>	Pirani gauge, non-bakeable, with integral, screened 3 metre lead
<b>PVB2</b>	Pirani gauge, bakeable, with integral, screened 3 metre lead
<b>AIG17P</b>	UHV Bayard-Alpert gauge, twin tungsten filaments with integral Pirani gauge
<b>AIGL3P</b>	Lead for AIG17P, screened, bakeable, 3metre
<b>PVX10</b>	10 metre, non-bakeable, screened Pirani extension lead

## Arun Microelectronics Ltd.

Fitzalan Road, Arundel,  
West Sussex BN18 9JP, England.  
Tel: 01903 884141 Fax: 01903 884119  
International Tel: +44 1903 884141  
www.arunmicro.com



*innovation in vacuum technology*