

Third - Generation UHV STEPPER MOTORS - Model C14.1

The C14.1 UHV-compatible stepper motor has 50% more output torque than the B14.1 motor it replaces. It is exactly the same size. The efficiency has been optimised so that the temperature rise is reduced at all power outputs and consequently outgassing is significantly less.

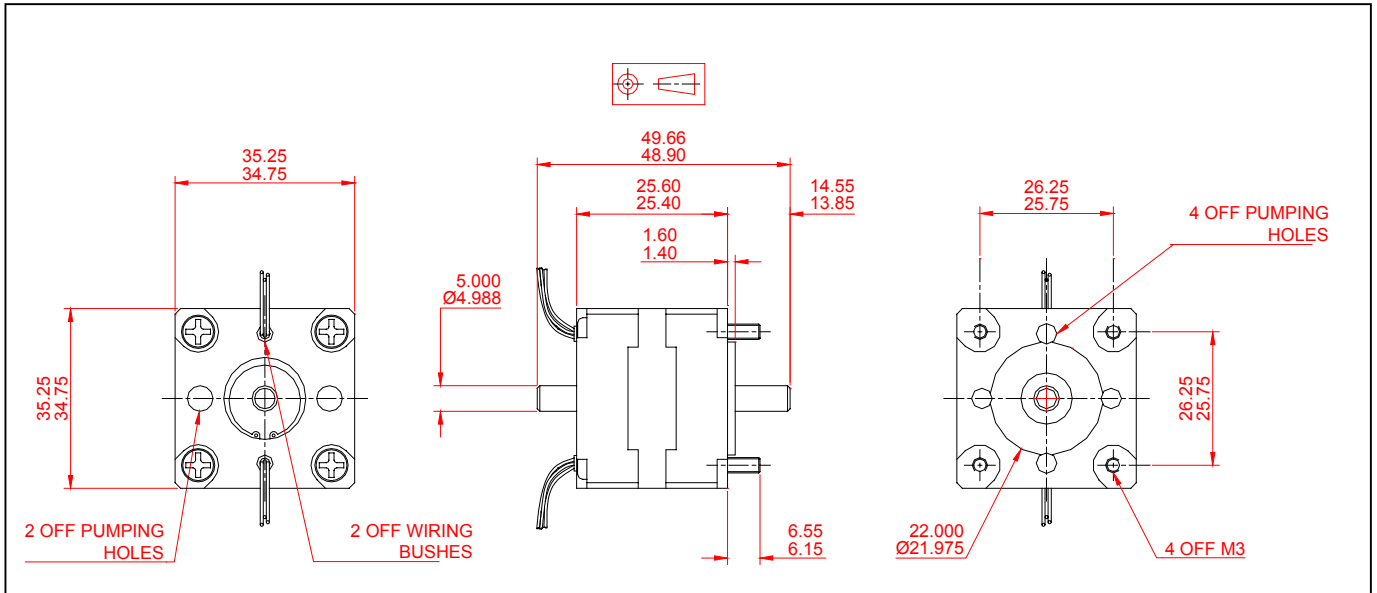

- ◆ Significantly higher torque. Drop-in replacement for B14.1 in all cases, resulting in significantly reduced gas load for the same power output.
- ◆ Proven technology: similar AML motors have been in constant use since 1986. Warranty returns are less than 0.2%
- ◆ Hybrid ceramic bearings for long life and reduced friction after multiple bakeouts.
- ◆ Greatly reduced outgassing and temperature rise due to advanced design, materials, surface finish and construction.
- ◆ All insulating materials are self-coloured polyimide or PEEK, with exceptional outgassing and insulating performance.
- ◆ Surfaces are etched and coated with DLC for increased emissivity and reduced outgassing.
- ◆ Open construction with all internal spaces ventilated.
- ◆ Very low particulate generation due to the absence of sliding metal contacts.
- ◆ Suitable for use below 1×10^{-10} mB.
- ◆ Bakeable to 200°C.
- ◆ Suitable for use in vacuum at 77°K.
- ◆ Radiation-hard versions are available.
- ◆ Electrical connections reduced to only 6 durable polyimide film-coated wires.
- ◆ Simplified connection with MLF18 bakeable lead, feedthrough and internal connector. Motors are supplied pre-wired to 1.5mm socket connectors compatible with MLF18.
- ◆ Dedicated drive, AML type SMD2 is available.
- ◆ Standard and radiation-hard motors are normally available from stock.

This document and the designs depicted are the copyright of Arun Microelectronics Ltd.. Specifications are typical and subject to change, confirm before ordering. E & OE.

AML acknowledges the rights of the owners of all trademarks and registered names.

AML

innovation in vacuum technology

SPECIFICATION

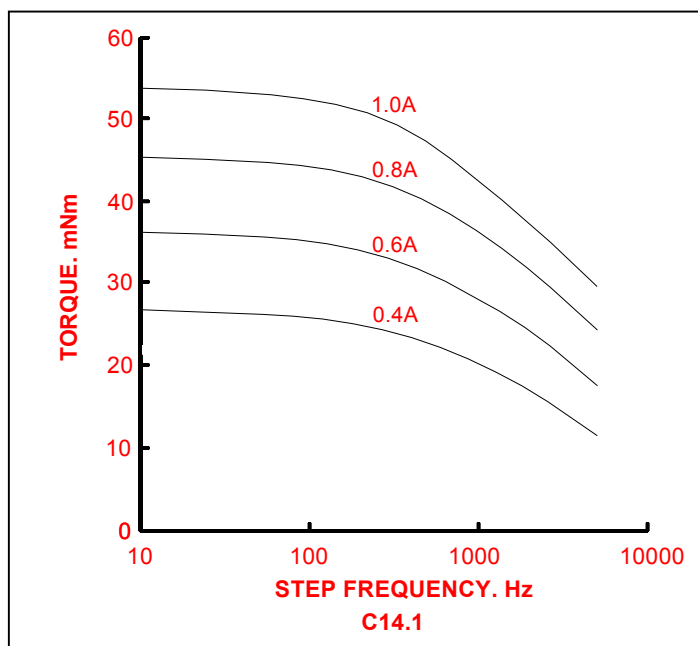

The performance shown on the graph was obtained using an SMD2 drive operating with standard settings for step division. SMD2 is a switch-mode, bipolar, current-regulating drive with a nominal source of 67volts, optimised for use with vacuum stepper motors. At low speeds where step division is active the RSS (root sum of squares) of phase current is set to the nominal current. Over most of the speed range the drive operates in wave mode with nominal set current in only one energised phase.

Different drives will produce different speed/torque curves and different temperature rise. Drives capable of producing a total phase current of more than 1A RSS may damage the insulation, even if the current is claimed to be adjustable. Drives with significantly lower source voltages will result in poor high-speed performance. Sufficient data are given below for drive selection. Use of the embedded thermocouple is essential for motor protection. AML do not recommend any drive other than SMD2.

Bakeout temperature	200°C	Phase resistance at 20°C	3.0Ohms
Operating temperature	-196°C to +175°C	Phase inductance	3.25mH
Step angle	1.8°	Holding torque (2 x 1A)	75mNm
Step angle tolerance (unloaded)	5%	(N.B Holding with two phases energised at 1A is not a recommended operating condition: see above)	
Power leads (Cu+Ag + Polyimide + FEP)	0.6mm ϕ	Detent Torque	5.5mNm
Power leads, rad-hard (Cu + Polyimide)	4 x 0.3mm ϕ	Weight	150g
K t/c leads (Polyimide)	0.2mm ϕ	Rotor inertia	10gcm ²
Lead length	1.35m	Motional voltage @ 1kHz(p-p)	4.2V
Shaft end-float	0.1 to 0.2 mm		

INSTALLATION / APPLICATION NOTES

The screws are fitted with metered torque. Do not disturb. Do not drop, demagnetise, disassemble, modify, touch or overheat the motor or allow particles to enter the bearings or pumping ports. AML will supply modified-shaft motors.

Identify the two power windings with a resistance meter. Reverse the connection of either winding to reverse rotation. The thermocouple alumel® wire (negative) is magnetic. A small magnet is provided for identification. AML will pre-wire motors to MLF18 VCF connectors at low cost.

The shaft end-float-control compression spring is fully exercised with an axial force of 3kg toward the rear of the motor. In linear mechanisms use gravity and/or apply an opposite axial pre-load to avoid adding end-float to backlash.

The bearings are silicon nitride balls in stainless steel with maximum static axial or radial load of 10kg.

Design mechanisms with balanced rotating loads and/or friction to maintain position with zero (or reduced) phase current for minimum outgassing. Use ministep only to smooth transitions: increase resolution by reduction gearing

Ensure ice cannot form in the motor if testing at low temperature in air. Avoid thermal shocks e.g. plunging in liquid nitrogen.

Motors are supplied pre-baked at HV. They will adsorb water in storage and handling. A 24-hour self-bake by SMD2, with an adequate pump, will achieve UHV-compatibility.

ORDERING INFORMATION: C14.1

add suffix **R** for radiation hardness to 1×10^7 Sv
add suffix **X** for shaft modification e.g. cross-hole, flat etc. Provide a sketch.



Arun Microelectronics Ltd

Fitzalan Road, Arundel,
West Sussex BN18 9JP, England.
Tel: 01903 884141 Fax: 01903 884119
International Tel: +44 1903 884141
www.vacuum-motors.com



sales:
tectra GmbH, Reuterweg 65,
60323 Frankfurt/M, Germany
Tel.: +49-69-720040,
Fax: +49-69-720400,
info@tectra.de, www.tectra.de